



External fire spread on houses



BY ED SOJA,
BRANZ SENIOR FIRE
SAFETY ENGINEER

WHEN RESIDENTIAL BUILDINGS HAVE A WALL LESS THAN 1 M (OR SOMETIMES 5 M) FROM THE BOUNDARY, THERE ARE REQUIREMENTS FOR THE BOUNDARY WALLS TO HAVE SPECIFIC FIRE RESISTANCE RATINGS (FRR) AND EXTERIOR SURFACE FINISHES.

EXTERNAL FIRE SPREAD is an important consideration for single household units and small multi-unit dwellings in order to protect the life of occupants and other property from the effects of fire.

C/AS1, the New Zealand Building Code Acceptable Solution for fire safety, covers several aspects of external fire spread:

- Fire spread across boundaries affecting other property.
- Fire spread from lower roofs.
- External surface finishes.

Carparks and similar construction are also covered.

Range of buildings covered

C/AS1 covers houses, townhouses, small multi-unit dwellings and limited area outbuildings, such as carports. Examples include:

- single household units
- multi-unit dwellings with no more than one unit above the other
- detached dwellings used as boarding houses for fewer than six people
- garages that are part of a household unit
- shared garages
- construction associated with these buildings, for example, sheds and sleepouts
- carports.

Magic 1 m from boundary

Usually houses are built at least 1 m from the boundary, but sometimes a tight section, alterations or the need for garages or other outbuildings means construction is under 1 m from the boundary.

In these cases, buildings under C/AS1 need the boundary walls to meet a fire resistance rating (FRR) and exterior surface finish specifications.

Single houses, attached dwellings and outbuildings

For single household units, attached side-by-side dwellings and outbuildings, walls less than 1 m and less than 90° from the boundary, must have a FRR of 30/30/30 (see Figure 1). This means that the system used for the wall must have achieved a FRR of at least 30/30/30 (structural adequacy/integrity/insulation) in the standard test AS 1530.4-2005.

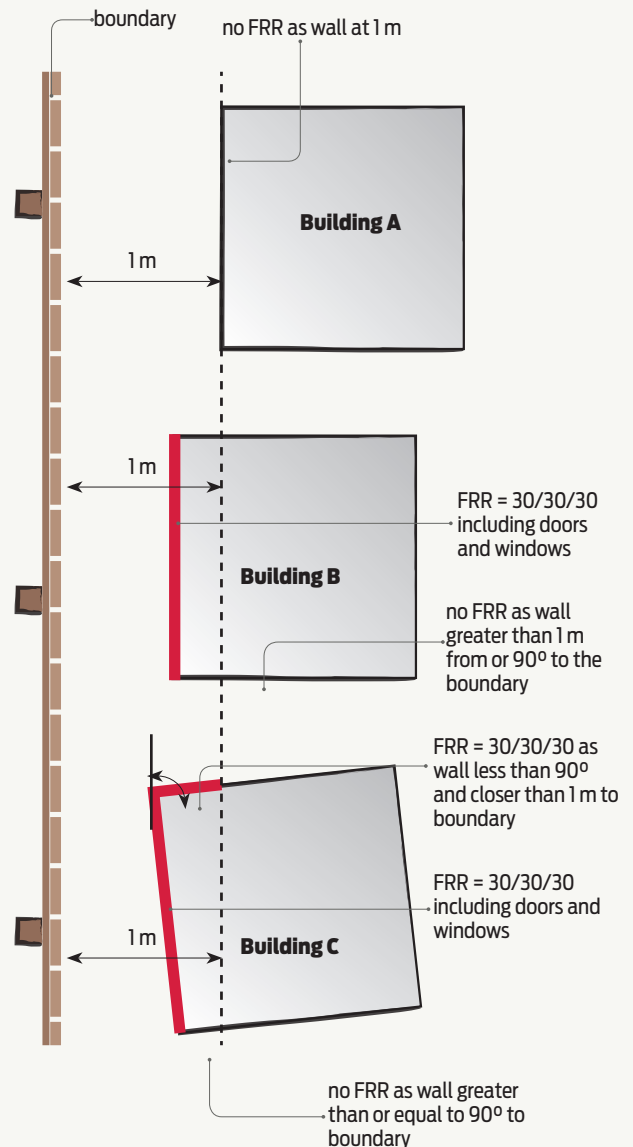

Figure 1

Fire ratings for various building orientations for single or attached dwellings and outbuildings.

Walls, including any return walls at less than 90° that are within 1 m of the boundary, need a FRR of 30/30/30 (see Building C in Figure 1).

Any windows and doors in those walls also need a FRR of 30/30/30. These doors and windows must be sourced from a proprietary supplier of fire-rated doors and windows.

Multi-unit dwelling

For buildings with no more than two vertical household units, the same essentially applies as for single household units except:

- windows at 1 m or closer to the boundary need an FRR of 30/30/30 (see Building E in Figure 2).

Eaves and walls

The two options for eaves (see Figure 3) are:

- protecting the underside of the eaves and wall
- extending the wall to the underside of the roof.

Where the eaves extend to within 650 mm of the boundary (see Figure 4), the eaves and wall must have a FRR of 30/30/30, even if the wall is greater than 1 m from the boundary and would otherwise not have a FRR.

The FRR required is 30/30/30 from both sides of a wall or underside of an eaves projection or roof. Various manufacturers offer many options for the wall construction to meet this requirements.

NZBC clause B1 *Structure* also applies as the walls are loadbearing. Most commonly, a house or garage will be built of timber framing. NZS 3604:2011 *Timber-framed buildings* defines the scope and design of timber-framed buildings and is an Acceptable Solution for meeting NZBC clause B1.

Protection from a lower roof

If there is an attached C/ASI-controlled building that is another property and one roof is lower than the other, then either:

- the roof must have a FRR of 30/30/30 for a distance of 5 m from the external wall, or
- the higher external wall must have a FRR of 30/30/30 for a height of 9 m, or ➤

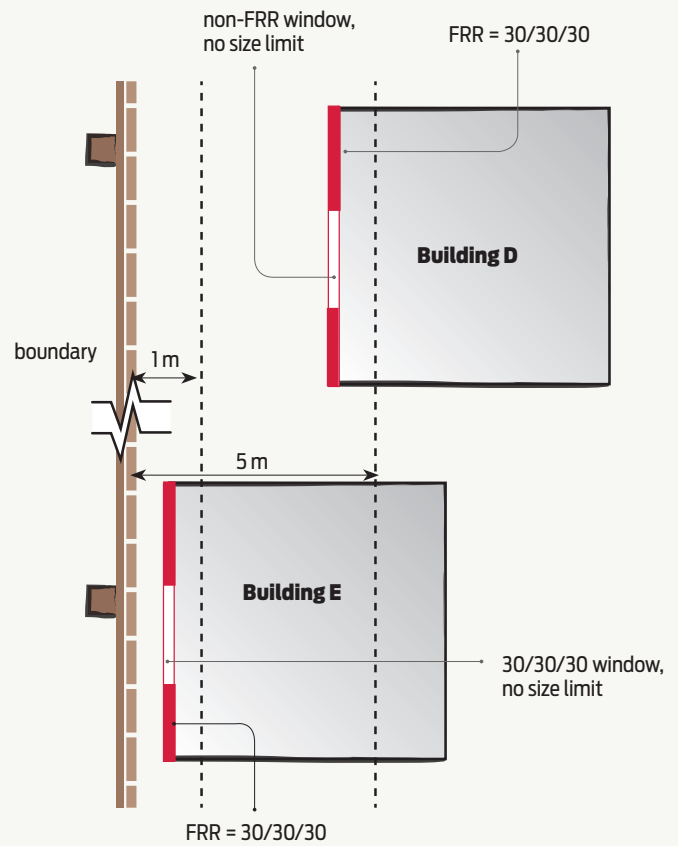

Figure 2 Fire rating for multi-unit dwelling.

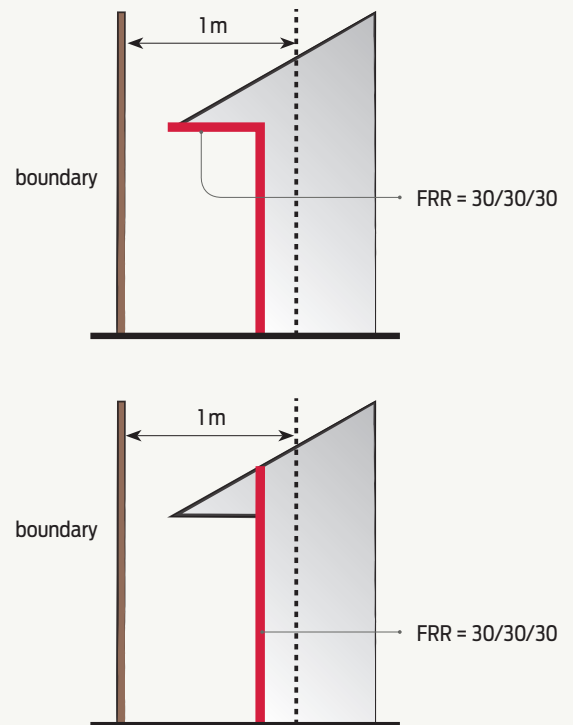

Figure 3 Two options for fire rating eaves.

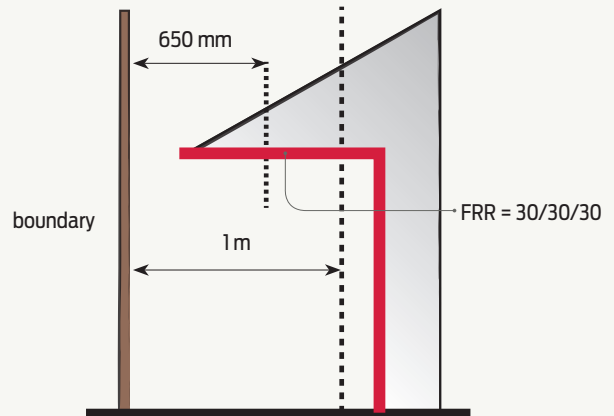

Figure 4 Eaves within 650 mm of boundary must have FRR.

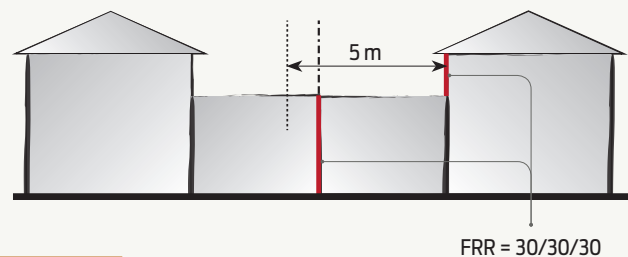
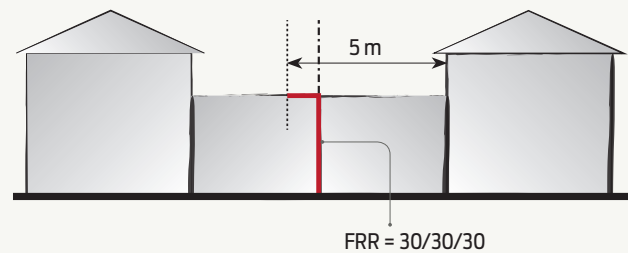

Figure 5 Protection from a lower roof.

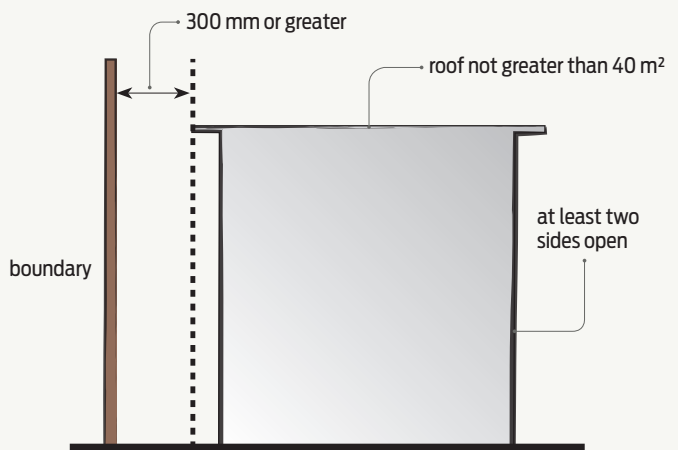

Figure 6 Carport and similar construction specifications.

- the building under the roof requiring a FRR is protected by a sprinkler system complying with NZS 4515:2009 *Fire sprinkler systems for life safety in sleeping occupancies (up to 2,000 m²)*.

Again, this also applies to any windows and penetrations in the wall.

The keywords here are 'attached', 'other property' and 'lower roof'. So where buildings are joined across a boundary (see Figure 5), either:

- the roof of one building within 5 m of the neighbour must be fire rated, or
- the wall above the roof level, 5 m or closer to the lower roof on another property, must be fire rated.

In these situations, the 1 m distance no longer applies.

Any separation, between the two buildings under separate title, no matter how small, removes this requirement.

Exterior surface finishes

There are specifications for fire spread on external walls for buildings:

- less than 1 m from the boundary
- more than 1 m but whose building height is greater than 10 m.

The requirements are given in terms of results from a cone calorimeter test to ISO 5660-1:2002.

Where the wall cladding is non-combustible and any applied coating, such as paint, is less than 1 mm thick, there are no requirements, and they can be at any distance to the boundary and at any height.

Where the combustibility of a timber product is modified through the application of a fire-retardant treatment to meet the requirements, it has to have been subjected to pretest accelerated weathering as described in C/AS1 Appendix C C7.1.3.

Carpports and similar construction

There are no requirements for a FRR on walls and supports when:

- at least two sides are completely open to the environment, and
- the carport and adjacent building are under the same ownership, and
- the roof plan area is no more than 40 m² and no part of the roof is closer than 300 mm to a relevant boundary. (Roof plans may be greater than 40 m² but must be more than 300 mm from the boundary.)

If any one of these is not satisfied, the FRR requirements above for houses and other outbuildings must be followed (see Figure 6). ◀