

BUILD
RIGHT



BY ALIDE ELKINK,
FREELANCE TECHNICAL
WRITER, WELLINGTON

External stairs for houses

EXTERNAL TIMBER STEPS CAN FEEL A BIT WOBBLY OR SPRINGY, ESPECIALLY AS THEY GET WIDER. WE REVIEW THE DESIGN RULES AND OFFER SOME IDEAS FOR BUILDING STRONG STAIRS.

External stairs on the access route into a house may provide access to a deck or across a sloping site. If they are part of the main access route to the house, they must comply with NZBC clause D1 *Access routes*.

The acceptable solution D1/AS1 is quite prescriptive, including requirements for stair pitch, riser height, tread depth, projections or nosings, where open risers may be used, stair width, handrails and slip resistance.

Design starts with stair type

External stair design should start by determining the classification. D1/AS1 classifies stairs as accessible, common or private according to their use.

A common stairway may be used by the public whether as of right or not. Where an external stairway forms part of the main access route to the house, it must be classified as a common stairway. Otherwise, it may be a main private stairway – one that is used by a single household unit only. Common and main private stairways have the same design requirements.

Work out the design limits

The next stage is to determine the design limits – the pitch, riser height and tread depth of the steps (see Figure 1). These are set out in D1/AS1 Table 6.

For common and main private stairways, the permitted dimensions in D1/AS1 are:

- maximum pitch – 37°
- maximum riser height – 190 mm
- minimum tread depth – 280 mm.

Where different tread, riser and pitchline configu-

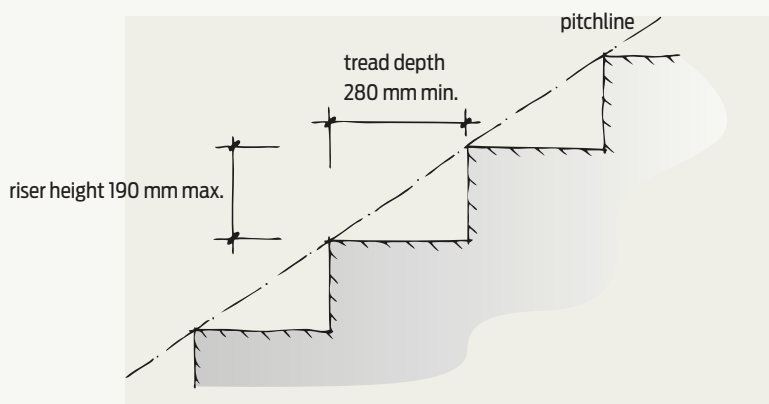

Figure 1 Pitchline, tread and riser dimensions for common and main private stairways.

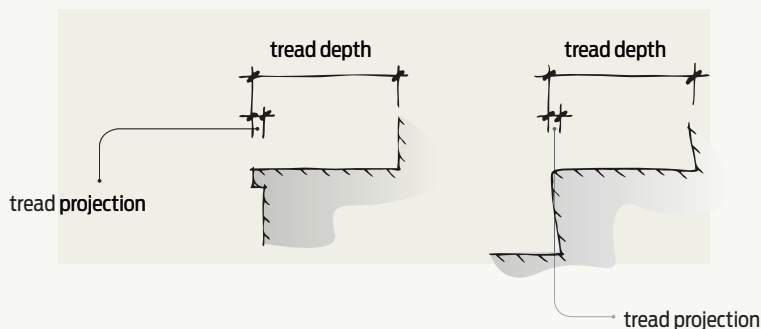

Figure 2 Examples of tread projections.

rations are required, these can be calculated from D1/AS1 Figure 11.

Tread and riser requirements

All the steps in a flight must be uniform with the same dimensions and no more than 5 mm variation. Uniformity is measured at the centre of straight flights of stairs and at the pitchline for curved stairways.

All stair treads must have a level surface and a wet and dry slip resistance – measured as the coefficient of friction – in accordance with D1/AS1 Table 2.

Open risers are allowed in common and private stairways but the open space between treads must not allow a 100 mm diameter sphere to pass through, and the leading edge of the treads must be a contrasting colour.

Calculating tread and riser sizes

The proposed stair is 2.5 m high (see Figure 3). Divide the height of the flight by the maximum riser height to calculate how many risers are required:

$$2500 / 190 = 13.16$$

The maximum allowed riser height is 190 mm, so 14 risers are needed.

Now, calculate the actual riser height:

$$2500 / 14 = 178.6 \text{ mm}$$

There is always one more riser than treads, so for 14 risers, there will be 13 treads. The minimum permitted tread depth is 280 mm, but with ample space for the stairs, 300 mm treads have been selected. Multiply the tread depth by the number of treads to calculate the overall length of the stair:

$$300 \times 13 = 3900 \text{ mm}$$

Each tread will also have a 20 mm projection, giving a total tread depth of 320 mm, but the projection does not add to the overall run (going) of the stair.

On site, builders must always check that the total rise is as calculated – if not, adjust the riser dimension.

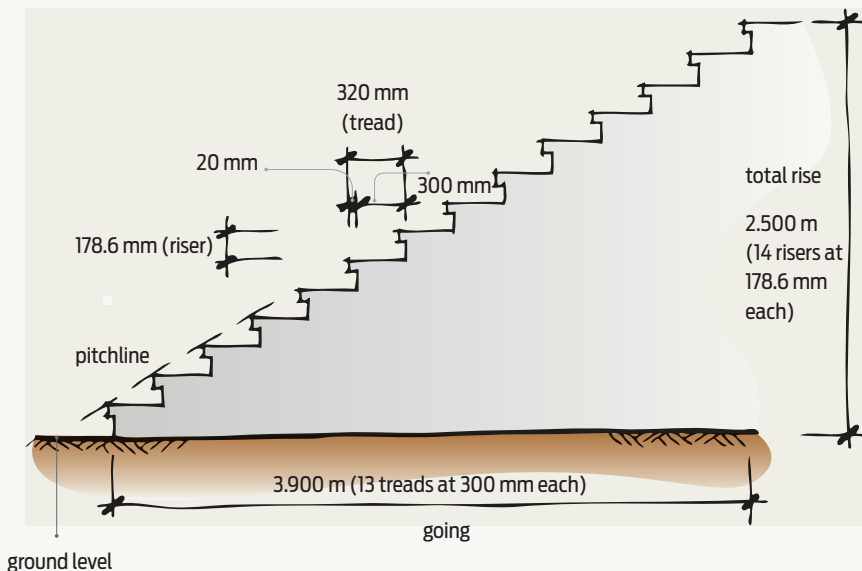

Figure 3 Stair layout example.

The leading edge of closed stair treads may be flush with or project up to 25 mm beyond the face of the riser below. For an open stair, the leading edge must project at least 15 mm over the tread below, up to a maximum 25 mm. For both stair types, the projection is considered part of the overall tread depth (see Figure 2).

While not required under D1/AS1, BRANZ also recommends:

- maintaining a clear view of the whole flight of stairs – avoid obstructions and winders or sharp turns where possible
- limiting the number of risers in a single flight to 17.

Stair width and landings

A common stairway must be at least 900 mm wide between handrails. While there is no

minimum width specified for other stairways in household units, D1/AS1 recommends 850 mm as a practical minimum width.

Landings are required at the top and bottom of all flights of stairs and wherever a door opens directly onto a stairway. The only exception is if the rise of the flight is less than 600 mm and no door opens over the steps. Landings must be at least the same width as the stairs and a minimum of 900 mm long.

D1/AS1 Table 7 sets out the maximum height between landings as no more than 2.5 m for a common stairway and 4 m for a private stairway.

Curved, spiral and winder stairways

Curved, spiral and winder stairways are permitted. They must meet the same requirements

as straight flight stairs, but the pitchline is measured:

- 300 mm from the outside curve of a stair when the stair is less than 1 m wide
- 300 mm from the inside curve of a stair when the stair is over 1 m wide.

For a winder stair, the pitchline is:

- measured at the centre of the stair when the stair is less than 1 m wide
- 300 mm from the inside curve of a stair (same as for curved stairs) when the stair is over 1 m wide.

Lighting levels

D1/AS1 Table 8 sets out stairway lighting level requirements. For safety, they should be lit, preferably automatically. ➤

Handrails and safety barrier design

Generally, common and private stairs that are less than 2 m wide and have more than two risers must have a handrail. However, a handrail can be omitted on stairs with two or three risers that access a single household unit.

Where required, handrails must have the same slope as the stairway pitchline, be 900–1000 mm high and have a profile as shown in DI/AS1 Figure 26(a).

If a fall of more than 1 m is possible, a safety barrier must be provided – the requirements are in NZBC clause F4 *Safety from falling*. The barrier must be able to withstand all imposed, wind and impact loads without collapsing, becoming unstable or deflecting unreasonably.

There is currently no compliance document for safety barriers, so all safety barriers must be specifically designed. A Ministry of Business, Innovation and Employment Building and Housing Group publication, *Guidance on barrier design*, provides some design and installation guidance.

Timber treatment

External stair timber generally should be graded SG8 (wet in use) *Pinus radiata*, treated to hazard class H3.2. Non-structural balustrade or infill timber may be merchantable grade, and timber in ground contact must be H5-treated.

Construction of treads/risers/strings

Strings span between the top and bottom of a stair flight. When treads are housed into strings, the strings are typically 290 × 45 mm, but other sizes may also be used (see Table 1 for maximum spans). Cutting steps into a string to support the treads is not recommended – it will compromise the timber treatment.

Treads spanning 900–1000 mm between strings should be nominal 50 mm thick minimum and grooved or have a slip-resistant finish. Boards should have 5 mm gaps between them. Treads may be fixed to strings:

- by being housed into a 13 mm rebate
- on timber or steel brackets/cleats
- on blocks added to the stair string to suit the tread and riser dimensions.

See Figures 4–6 for details.

For a wide stair, add mid-span strings for support. Although stairs up to 1.5 m wide may not

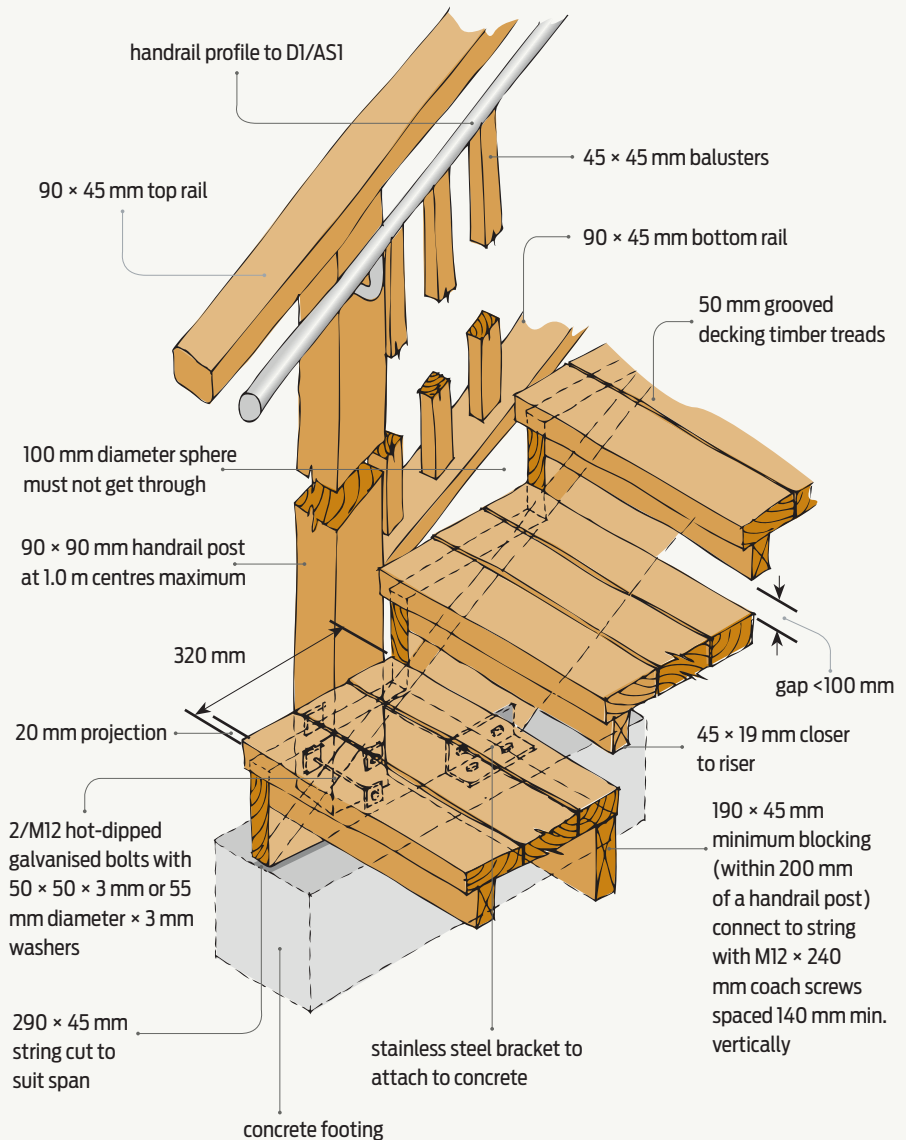

Figure 4 Stair construction.

Table 1

BRANZ MAXIMUM SPAN FOR SG8 (H3.2) STRING SIZES.

STRING SIZE	MAXIMUM SPAN
290 × 45 mm	4.0 m
240 × 45 mm	3.3 m
190 × 45 mm	2.6 m
140 × 45 mm	1.9 m

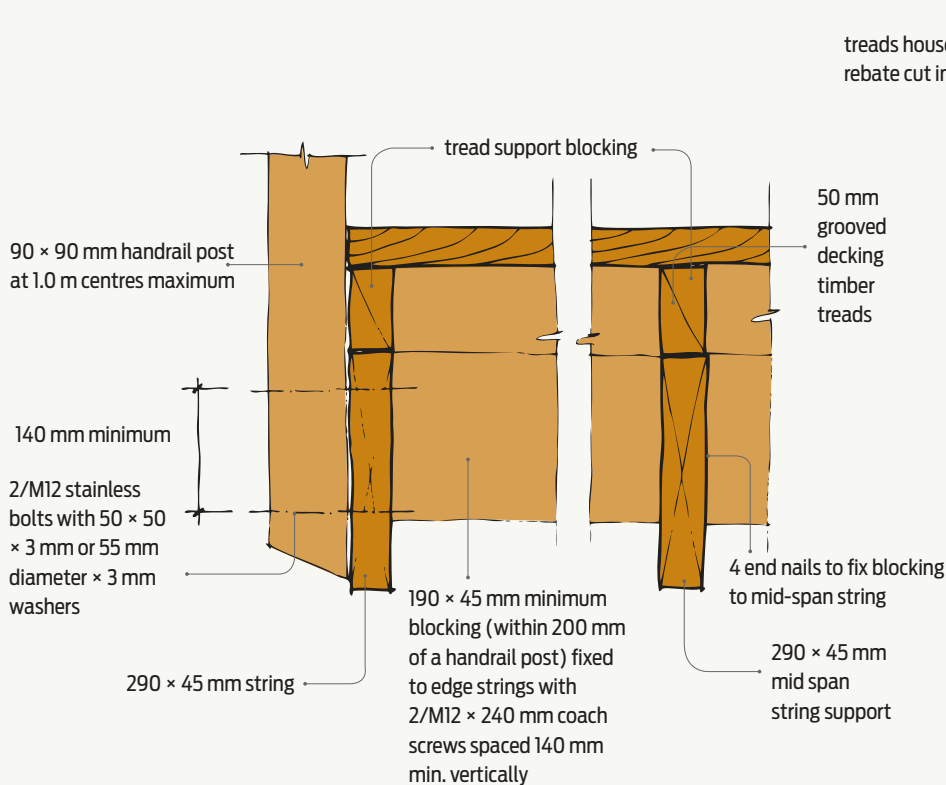

Figure 5 Handrail post fixing to stair string and mid-span string for wider stairs.

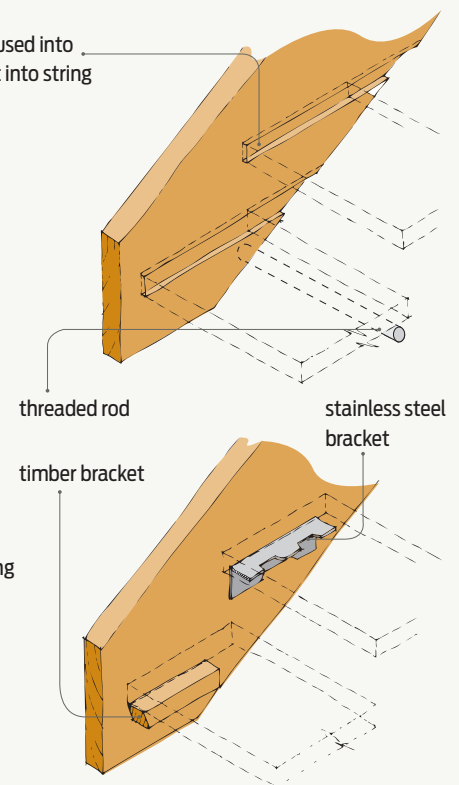

Figure 6 Alternate tread fixings.

need a mid-span string, sagging and deflection will be minimised by adding strings at 1.2 m centres for extra support.

To stiffen stairs and stop the strings from spreading, 12 mm diameter threaded rods tying strings together spaced at 1.2 m maximum should be used.

DI/ASI allows a common stairway to have open risers as long as the gaps are not large enough for a 100 mm diameter sphere to pass through. The proposed stair (see Figure 4) will need minimum 45 x 19 mm blocking to meet the DI/ASI requirement.

Support for strings

Strings may be fixed at the top to a boundary or edge joist using joist hangers and supported at the bottom with stainless steel post brackets or timber cleats on a concrete footing (see Figure 4).

Concrete footings should be at least 200 mm square x 200 mm deep with cast-in post brackets or bolts for cleat fixing. Alternatively, strings may be supported by being bolted to the timber posts

using two M12 bolts per post, with the H5 post set in minimum 200 mm square x 200 mm deep concrete footings.

Handrails and handrail posts

Structural posts are 90 mm square and fixed at 1 m maximum centres to each string with two M12 bolts. Give stability to strings and posts with 190 x 45 mm minimum blocking fixed between strings with two M12 x 240 mm coach screws at each end (see Figures 4 and 5). The blocking must be within 200 mm of each handrail post.

Handrails should be to profiles in accordance with DI/ASI Figure 26.

Top and bottom rails spanning between the structural posts support the balustrade or infill panels. They should be 90 x 45 mm and fixed to the posts with 4/100 x 3.75 mm nails. Balustrades of either 45 x 45 mm or 125 x 25 mm infill timber are fixed vertically to top and bottom rails when they are used or between the handrail and the string. ◀

Stair terminology

Tread – the horizontal surface of the step.

Riser – the vertical component of the step used to connect treads.

String or stringer – the inclined timber member on each side of the stairs that supports treads and risers.

Flight – series of steps without a landing.

Landing – a level platform at the top or bottom of a flight of stairs.

Handrail – a rail that is at the same slope as the pitchline to provide support for people ascending or descending the stair. Handrails must be 900–1000 mm above the pitchline.

Pitchline – the line joining the leading edge of successive stair treads in a single flight of stairs.